

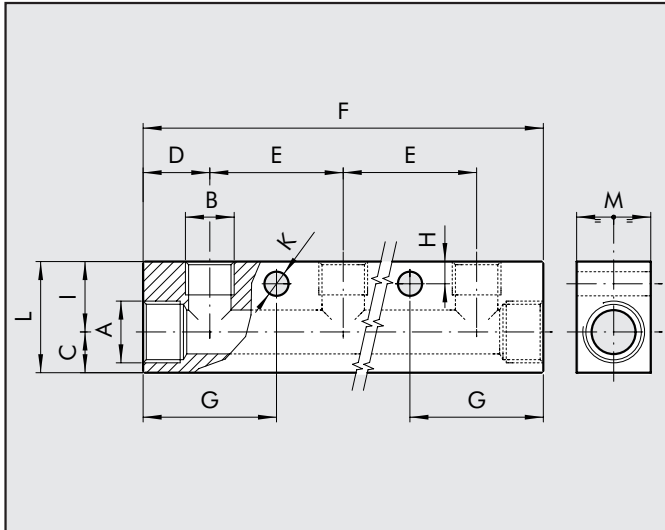

DISTRIBUTION FRAME

DISTRIBUTION FRAME WITH MULTIPLE STRAIGHT 1/4" OUTLETS



Code	INLETS		OUTLETS		D	E	F	G	H	K	I	C	L	M
	N°	A	N°	B										
W0502121006	2	G 3/8	3	G 1/4	18	36	108	36	6	6.5	19	11	30	20
W0502121008	2	G 3/8	4	G 1/4	18	36	144	36	6	6.5	19	11	30	20
W0502121010	2	G 3/8	5	G 1/4	18	36	180	36	6	6.5	19	11	30	20
W0502121012	2	G 3/8	6	G 1/4	18	36	216	36	6	6.5	19	11	30	20
W0502131006	2	G 1/2	3	G 1/4	18	36	108	36	6	6.5	24	16	40	30
W0502131008	2	G 1/2	4	G 1/4	18	36	144	36	6	6.5	24	16	40	30
W0502131010	2	G 1/2	5	G 1/4	18	36	180	36	6	6.5	24	16	40	30
W0502131012	2	G 1/2	6	G 1/4	18	36	216	36	6	6.5	24	16	40	30

DISTRIBUTION FRAME WITH MULTIPLE STRAIGHT 1/8" OUTLETS

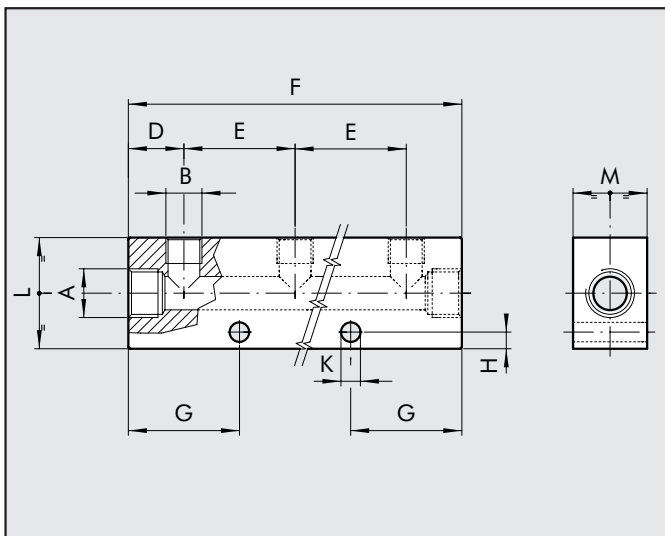

Code	INLETS		OUTLETS		D	E	F	G	H	K	L	M
	N°	A	N°	B								
W0502111005	2	G 1/4	3	G 1/8	15	30	90	30	4.5	5.3	30	20
W0502111007	2	G 1/4	4	G 1/8	15	30	120	30	4.5	5.3	30	20
W0502111009	2	G 1/4	5	G 1/8	15	30	150	30	4.5	5.3	30	20
W0502111011	2	G 1/4	6	G 1/8	15	30	180	30	4.5	5.3	30	20

DISTRIBUTION FRAME WITH 2 OPPOSED OULETS

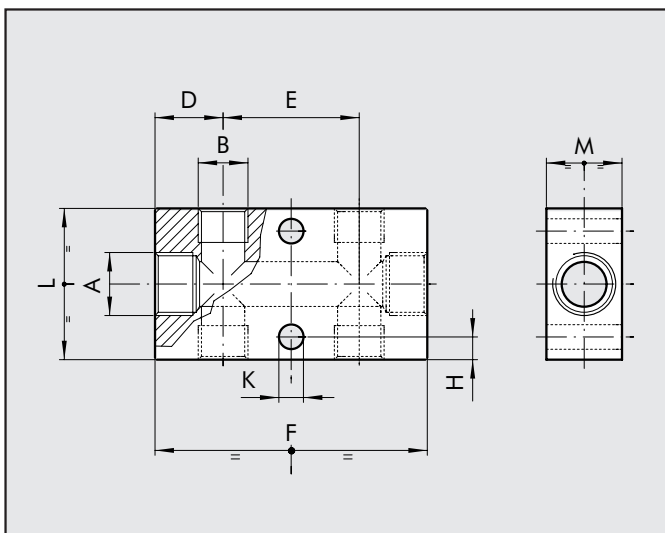

Code	INLETS		OUTLETS		D	E	F	H	K	L	M
	N°	A	N°	B							
W0503111013	2	G 1/4	2+2	G 1/8	15	30	60	4.5	5.3	30	20
W0503121014	2	G 3/8	2+2	G 1/4	18	36	72	6	6.5	40	20
W0503131014	2	G 1/2	2+2	G 1/4	22	36	80	6	6.5	40	30

DISTRIBUTION FRAME WITH 1/8"-1/4" OPPOSED OUTLETS

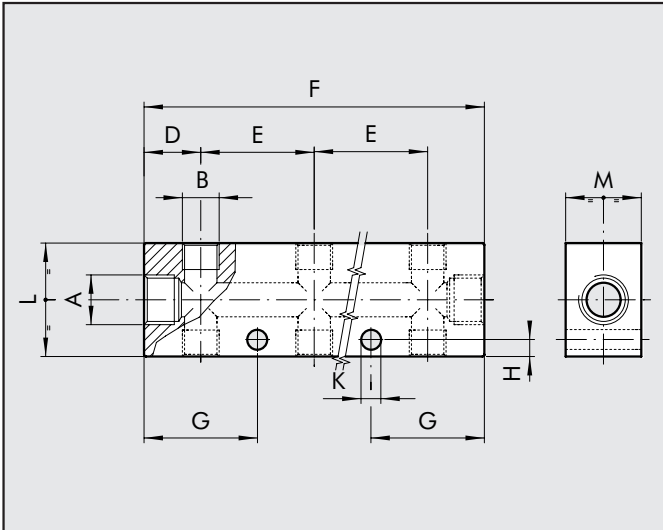

Code	INLETS		OUTLETS		D	E	F	G	H	K	L	M
	N°	A	N°	B								
W0503111015	2	G 1/4	3+3	G 1/8	15	30	90	30	4.5	5.3	30	20
W0503111017	2	G 1/4	4+4	G 1/8	15	30	120	30	4.5	5.3	30	20
W0503111019	2	G 1/4	5+5	G 1/8	15	30	150	30	4.5	5.3	30	20
W0503121016	2	G 3/8	3+3	G 1/4	18	36	108	36	6	6.5	40	20
W0503121018	2	G 3/8	4+4	G 1/4	18	36	144	36	6	6.5	40	20
W0503121020	2	G 3/8	5+5	G 1/4	18	36	180	36	6	6.5	40	20
W0503131016	2	G 1/2	3+3	G 1/4	22	36	116	40	6	6.5	40	30
W0503131018	2	G 1/2	4+4	G 1/4	22	36	152	40	6	6.5	40	30
W0503131020	2	G 1/2	5+5	G 1/4	22	36	188	40	6	6.5	40	30

DISTRIBUTOR, Ø 4-6-8 mm

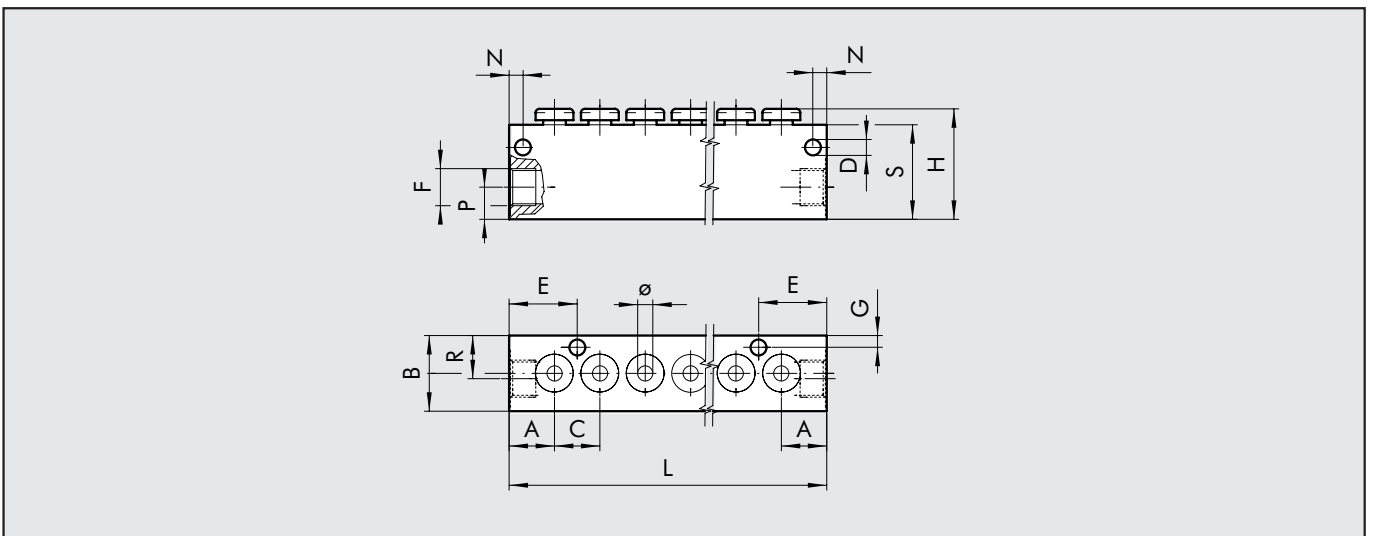

Code	N. positions	Ø	F	A	B	C	D	E	G	H	L	M	N	P	R	S
7304106	6	4	1/8	12	20	12	4.2	3.7	3.1	29	84	6	3.7	8.5	11.4	25
7304112	12	4									156					
7306206	6	6	1/4	14	20	14.6	4.2	21.3	3.1	34	101	6	3.7	10	11	30
7306212	12	6									188.6					
7308306	6	8	3/8	18	25	16.6	4.2	26.3	4.2	39	119	5	5	14	14	35
7308312	12	8									218.6					



ROTARY JOINT

SINGLE ROTARY JOINT

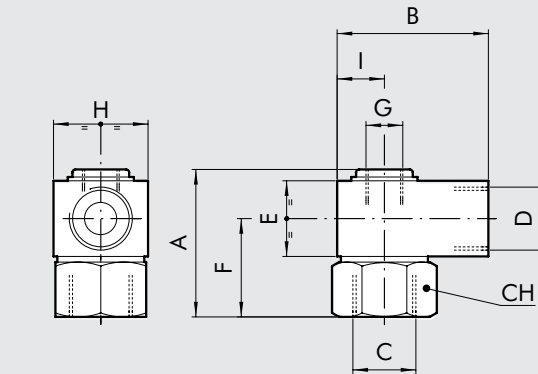

Code	A	B	C	D	E	F	G	H	I	CH	r.p.m.
W0511101101	32	30	G 1/8	G 1/8	16	22	-	16	8	16	550
W0511121121	32	30	G 1/4	G 1/4	16	22	-	16	8	16	550
W0511131131	39	40	G 3/8	G 3/8	20	26	G 1/8	25	12.5	24	300
W0511141141	55	65	G 1/2	G 1/2	30	35	G 3/8	40	20	30	200
W0511151151	70	65	G 3/4	G 3/4	40	45	G 1/2	40	20	36	160
W0511161161	80	80	G 1	G 1	45	52.5	G 3/4	50	26	45	140

MULTIPLE ROTARY JOINT

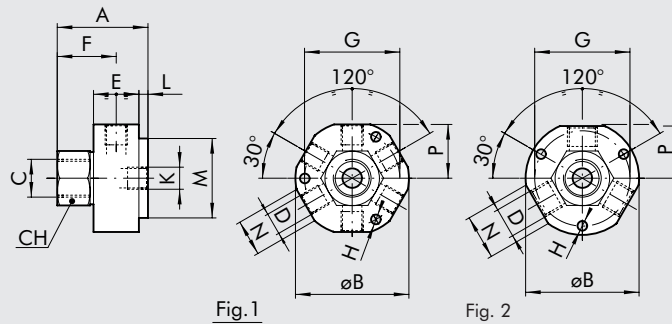

Code	Figure	A	B	INLET		OUTLET		E	F	G	H	K	L	M	N	P	CH	r.p.m.
				N°	C	N°	D											
W0513131101	1	40	50	1	G 3/8	6	G 1/8	20	26	42	4.2	G 1/8	4	35	16	23.7	24	300
W0512131121	2	40	50	1	G 3/8	3	G 1/4	20	26	42	4.2	G 1/4	4	35	19	23	24	300

2 INDEPENDENT WAY ROTARY JOINTS

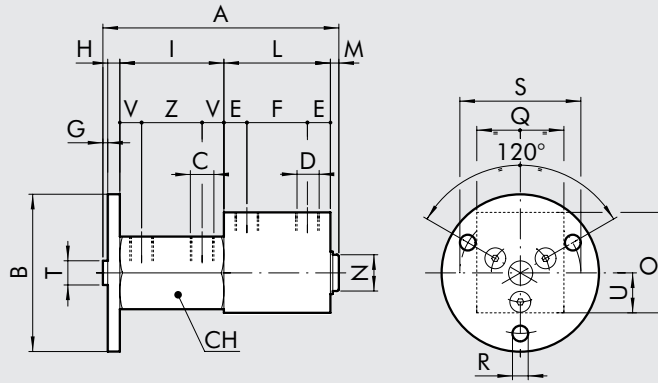

Code	A	B	INLETS		OUTLETS		E	F	G	H	I	L	M	N	O	Q	R	S	T	U	V	Z	CH	r.p.m.
			N°	C	N°	D																		
W0514101101	97.5	64	2	G 1/8	2	G 1/8	9.5	25	2	5	43	44	3.5	15	25	25	6.3	50	10	12.5	9	25	30	300
W0514121121	132	64	2	G 1/4	2	G 1/4	15	30	2	5	60	60	5	24.5	40	40	6.3	50	10	20	15	30	36	200

3 INDEPENDENT WAY ROTARY JOINTS

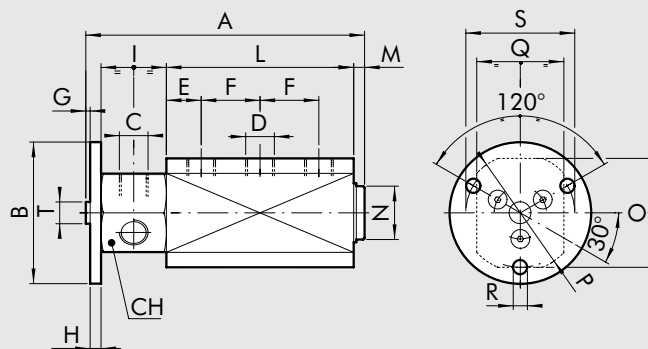

Code	A	B	INLETS		OUTLETS		E	F	G	H	I	L	M	N	O	P	Q	R	S	T	CH	r.p.m.
			N°	C	N°	D																
W0515121121	128	64	3	G 1/4	3	G 1/4	16	27	2	5	30	86	5	24.5	50	54	40	6.3	50	10	36	200